

Zenair Europe

Service Letter



This Service Letter (SL) has been issued by Zenair S.A.R.L. (Europe).

S.L. Number:	ZE-2009-01
Date of issue:	June 1, 2009
Subject:	Verification of the proper installation of the “Flap Stops” (Part N° 6S3-1)
Affected Models:	All Zenair Zodiac CH 601XL/CH 650 (ULM and Homebuilt Models).
Serial Number(s)	All
Manufactured by:	Czech Aircraft Works (CZAW) and others.
Purpose:	The purpose of this S.L. is to ensure that all affected models are only flown when “Flap Stops” are installed.
Directed Action(s):	<p>a) Before the next flight, inspect the outboard area of the flap gaps on the top surface of each wing, to establish that the “Flap Stops” have been properly installed (see illustrations on page 2).</p> <p>b) When properly installed, the flaps come to rest against the “Flap Stops” when in the “up” (retracted) position. There should be no free-play at the trailing edge of the flaps when flaps are in the “up” position (snug against the Flap Stop).</p> <p>c) If not installed (see photo below), obtain and install the missing parts according to this S.L. before the next flight.</p> <div data-bbox="764 1274 1212 1536" data-label="Image"> </div>
Effective date:	Immediately.
Compliance:	Before the next flight.
References:	<ul style="list-style-type: none"> • Zenair Zodiac Plans 4th edition, Page 6-S-3 • Page 2 of S.L. # ZE-2009-01

Remarks:

Compliance with this Service Letter should be recorded in the aircraft's maintenance log.

Address inquiries concerning this Service Bulletin to your nearest Zenair representative or to:

Zenair Sarl Z.I. No.2 A rodr me de Valenciennes 59121 Prouvy, France

Tel: 0033-(0)6-89-26-27-98 e-mail: Europe@zenair.com

www.zenairulm.com

Procedure for compliance with ZE-2009-01:

1) When in the “up” position, the flap must rest against a plastic “flap stop” (see photos below). Both left and right flaps must be touching the stops when flaps are retracted (“up”).

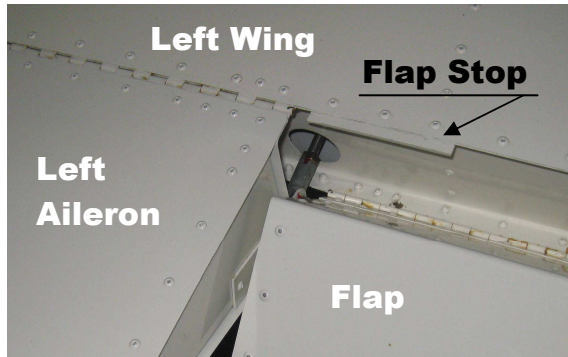

Left flap shown in “down” position

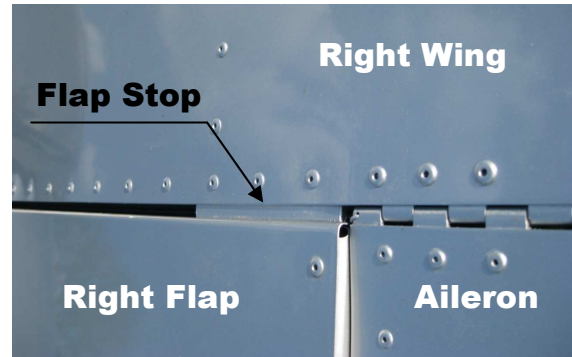

Flap up (against the flap stop)

2) There should be no free-play in the flaps when they are in the “up” position (test by applying light up-then-down pressure to the trailing edge). When flap stop (6S3-1) is installed as illustrated, no further action is necessary.

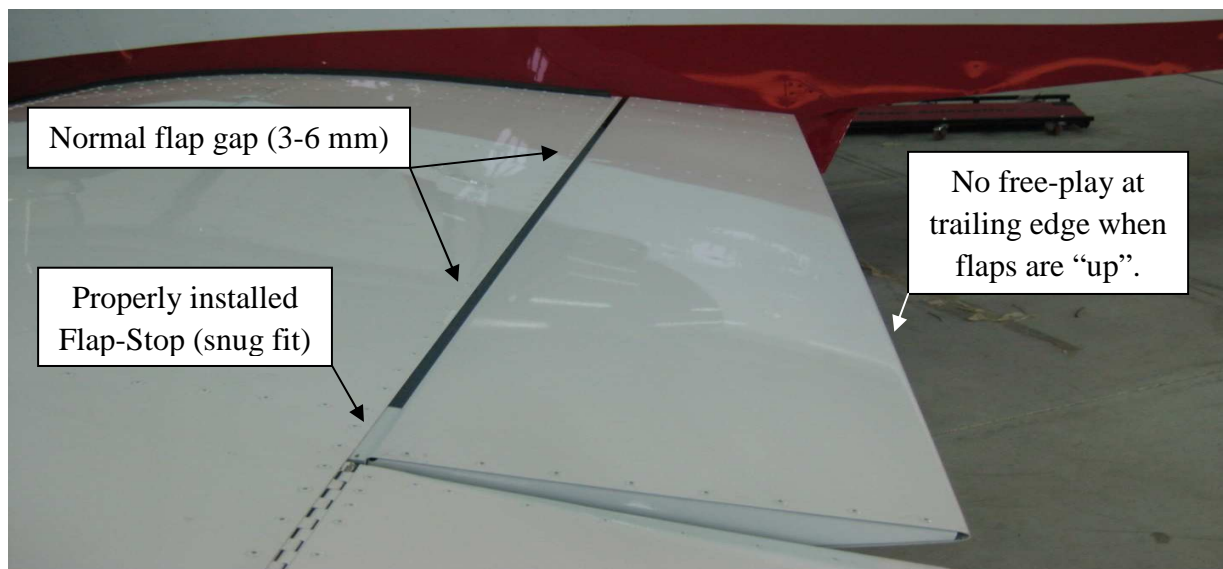

3) If Flap Stops are missing, order and install the parts by first drilling out the three corresponding rivets at trailing edge; position the plastic stops so that flaps just touch them in the up position and tape in place. Use existing rivet holes to position drill bit (#20 or 4mm) and drill through plastic. Remove tape and any burrs, rivet in place with three A5 Avex rivets or equivalent. Apply desired finish. Caution: If using Zenair-supplied rivets, the correct riveter-head must be used on the riveting tool!

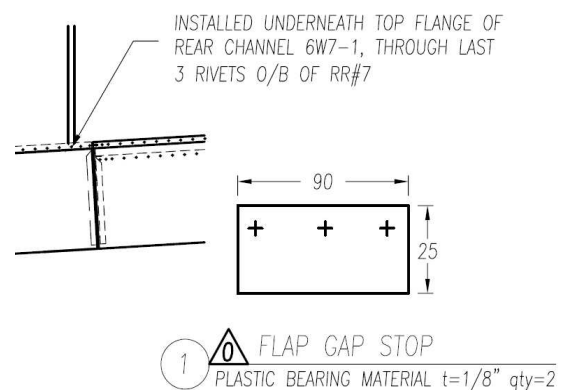

For assistance with the above process or for help translating these instructions, contact a regional Zenair representative near you. Visit www.zenairulm.com for closest dealer contact information.